



VRM SPARE PARTS LISTING

General Notes:

Always replace parts using LRC Coil parts for maximum life from the unit.

**DISCONNECT POWER BEFORE SERVICING UNIT OR INJURY
MAY RESULT**

Interpreting Serial Numbers

LRC Coil serial numbers are arranged with a unique serial number and date code.

#####-YYMM

- unique serial number
YYMM – Year Month of manufacture

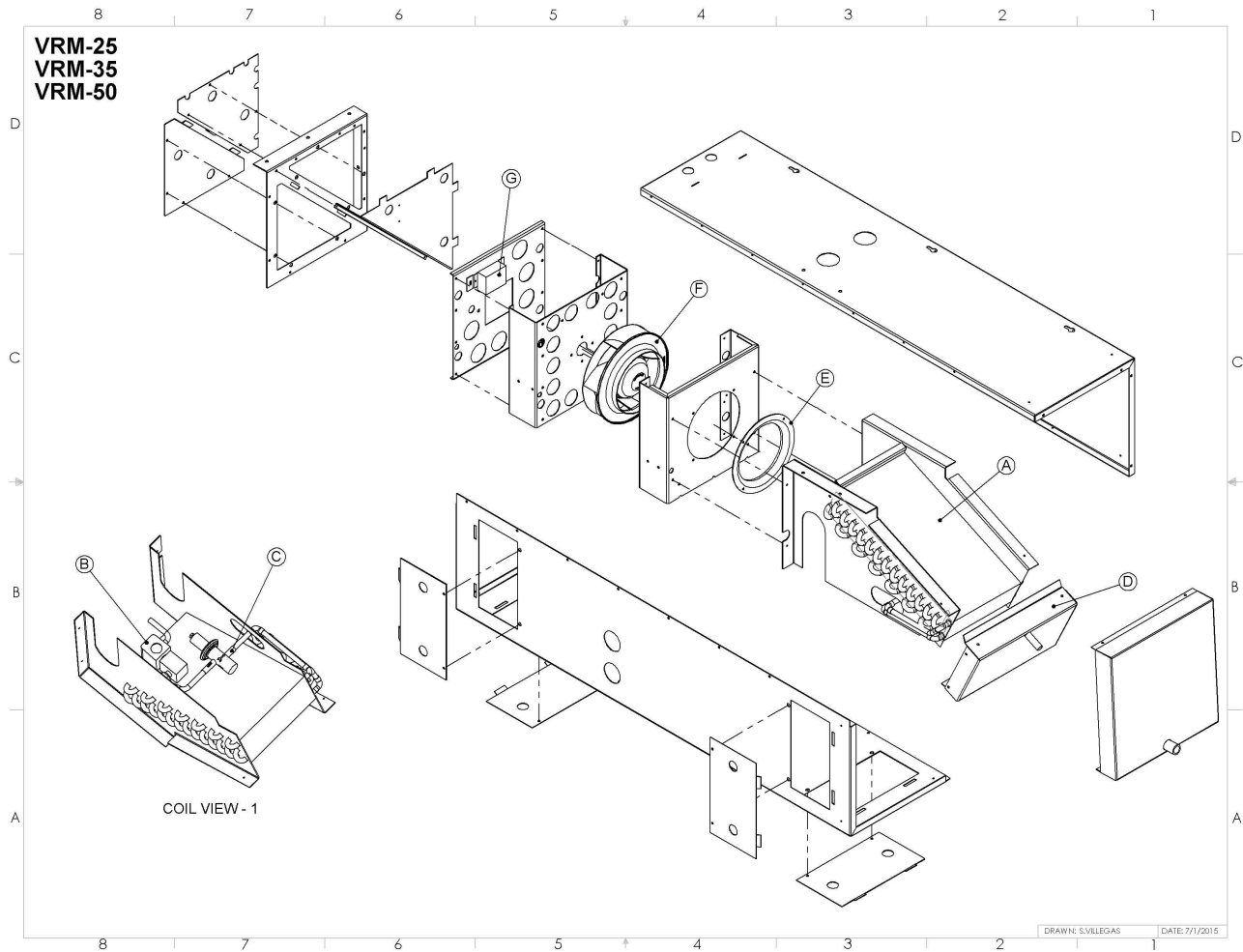

Note: Pre 2014 a 2 port (internally equalized) AXV was used. After that a 3 port (externally equalized) AXV was used. Always verify which configuration the customer wants. It is recommended that a 3 port/externally equalized valve be used for maximum system reliability.

Model	Part Description	PN	Comment
VRM-25	A-Coil Assy-includes coil, coating, AXV, LLSV	23084-02	Coil assy is coated, w/ AXV, LLSV, Not coated pre-2009
	B-LLSV-Sol+Valve (120vac coil)	2351 + 2760	Recommended to replace both
	B(optional) -LLSV-Sol+Valve (24vac coil)	2351+3130	Recommended to replace both
	C-AXV	2 Port - 2847	Pre late 2014 – verify config.
		3 Port - 3628	Recommended
	D-Drain Pan	23091-05	Stainless Steel
	E-Inlet Ring	Part of Impeller Kit	Replace as part of set
	F-Impeller	2274-kit (120V, PSC) 3414-kit (230V, PSC) 4074 (120V, ECM)	Impeller, ring and capacitor
	G-Speed Ctrl	2953 (120V) 3653 (230V)	2.5 Amp (do not use on EC models)
VRM-35	A-Coil Assy-includes coil, coating, AXV, LLSV	25463-00	Coil assy is coated, w/ AXV, LLSV, Not coated pre-2009
	B-LLSV-Sol+Valve (120vac coil)	2351 + 2760	Recommended to replace both
	B(optional) -LLSV-Sol+Valve (24vac coil)	2351+3130	Recommended to replace both
	C-AXV	2 Port - 2847	Pre late 2014 – verify config.
		3 Port - 3628	Recommended
	D-Drain Pan	23091-05	Stainless Steel
	E-Inlet Ring	Part of Impeller Kit	Replace as part of set
	F-Impeller	2274-kit (120V, PSC) 3414-kit (230V, PSC) 4074 (120V, ECM)	Impeller, ring and capacitor
	G-Speed Ctrl	2953 (120V) 3653 (230V)	2.5 Amp (do not use on EC models)

Model	Part Description	PN	Comment
VRM-50	A-Coil Assy-includes coil, coating, AXV, LLSV	24013-00	Coil assy is coated, w/ AXV, LLSV, Not coated pre-2009
	B-LLSV-Sol+Valve (120vac coil)	2351 + 2760	Recommended to replace both
	B(optional) -LLSV-Sol+Valve (24vac coil)	2351+3130	Recommended to replace both
	C-AXV	2 Port - 2847	Pre late 2014 – verify config.
		3 Port - 3628	Recommended
	D-Drain Pan	23091-05	Aluminum w/ coating
	E-Inlet Ring	Part of Impeller Kit	Replace as part of set
	F-Impeller	2274-kit (120V, PSC) 3414-kit (230V, PSC) 4074 (120V, ECM)	Impeller, ring and capacitor
	G-Speed Ctrl	2953 (120V) 3653 (230V)	2.5 Amp (do not use on EC models)
VRM-65	A-Coil Assy-includes coil, coating, AXV, LLSV	24114-11	Coil assy is coated, w/ AXV, LLSV, Not coated pre-2009
	B-LLSV-Sol+Valve (120vac coil)	2351 + 2760	Recommended to replace both
	B(optional) -LLSV-Sol+Valve (24vac coil)	2351+3130	Recommended to replace both
	C-AXV	2 Port - 2847	Pre late 2014 – verify config.
		3 Port - 3628	Recommended
	D-Drain Pan	24113-40	Aluminum w/ coating
	E-Inlet Ring	Part of Impeller Kit	Replace as part of set
	F-Impeller	2848-kit (120V, PSC) 3414-kit (230V, PSC) 4074 (120V, ECM)	Impeller, ring and capacitor
	G-Speed Ctrl	2953 (120V) 3653 (230V)	2.5 Amp (do not use on EC models)

Note: a significant change was made to the VRM-65 in 6/2015. Always verify which generation is being queried for coil replacement.