

BK SERIES

Technical Brochure

Revision date: 190429



PRODUCT OVERVIEW

The BK17-40 is designed for small to medium rooms. It is made for either new builds or to replace models from other brands that have the same footprint. BK17-40 comes standard with an energy efficient motor that is Title 24 compliant. Made to control temperature and humidity.

- In-room split system unit
- The unit comes standard with a universal AXV Valve and a Liquid Line Solenoid Valve for easy pump down installation
- Coil coated with a non-toxic water-based epoxy coating
- Standard black coated aluminum housing
- Digital controller with a sensor
- 230 volt available upon request
- Stainless Steel drain pan with a 3/4" NPT

MODEL NUMBER: BK17-40

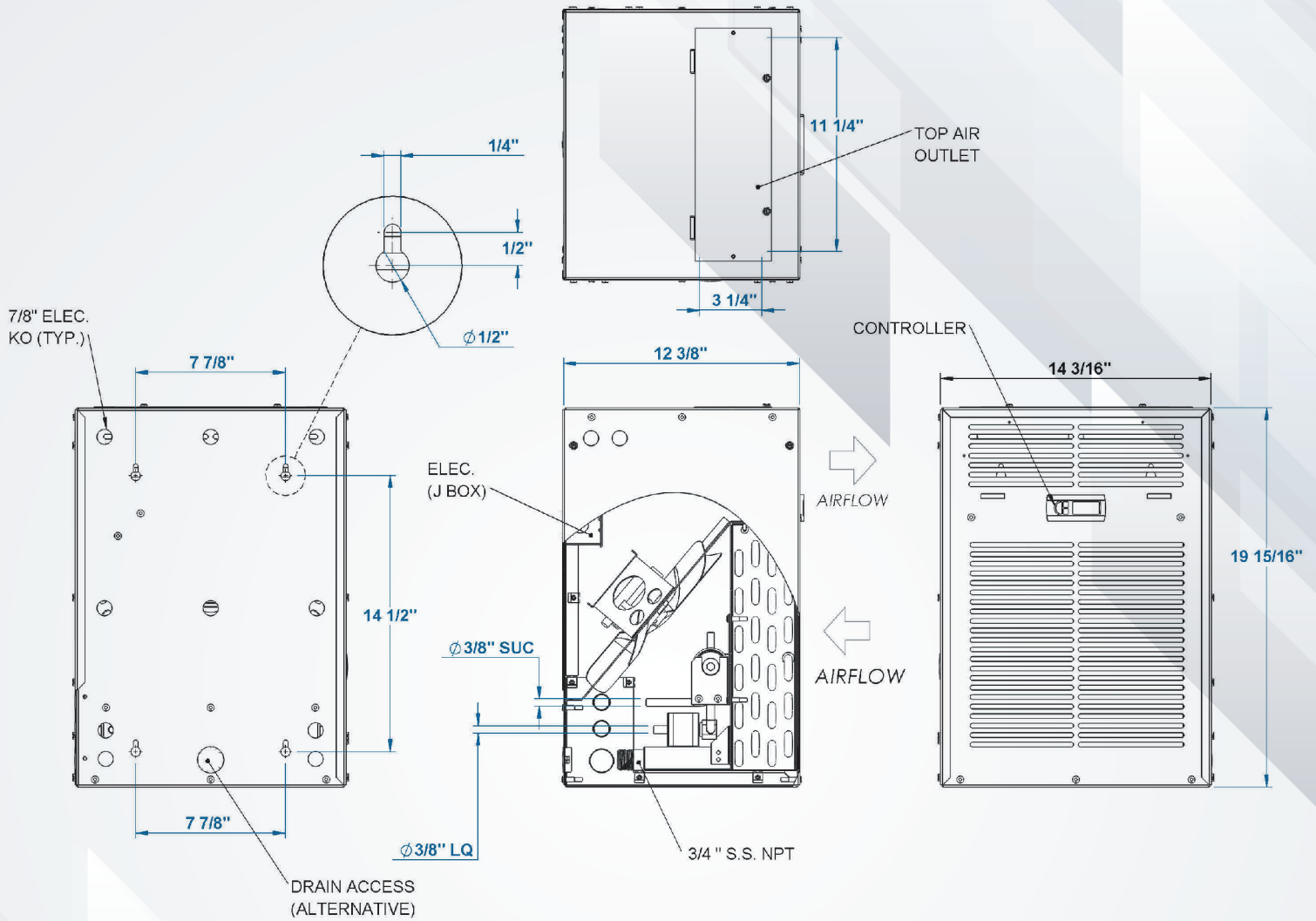

SPECIFICATIONS:

MODEL NUMBER	CAPACITY/BTUH @ A 17° TD, 38°SST, EAT 55°								MOTOR			CONNECT-IONS		DIMENSIONS			APPRX SHIP WT. (LBS)
	R-22	R-134A	R-404A	R-407C	R-448A	R-449A	R-452A	R-513A	QTY	AMPS	CFM	LIQUID	SUCTION	H	W	D	
BK17-40	3914	3902	4167	3792	4149	3654	4521	4164	1	.71	350	3/8	3/8	1915/16	14 3/16	12 3/8	30

Santa Fe Springs, CA
Office: 562.944.1969
Fax: 562.944.4979

